

UPS INTERFACE MODULE

PSMN2RB10

UPS Power Control Center, 10 Amp Switch / Circuit Breaker, 120 Vac, 2 Outlets, Terminals, 2.75" Track Mount

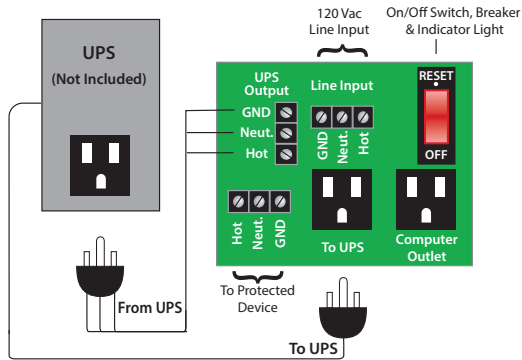

**BUY SEPARATELY
AND PLACE IN
AN ENCLOSURE
OF YOUR CHOICE**

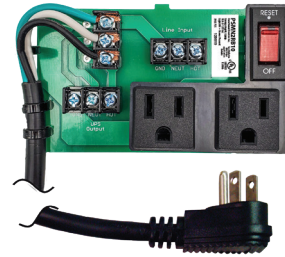

SPECIFICATIONS

- Operating Temperature:** -30 to 140° F
- Humidity Range:** 5 to 95% (noncondensing)
- Main Breaker ON/OFF:** Switch / Breaker (10 Amp)
- Dimensions:** 4.75"H x 2.75"W x 1.25"D1/1.75"D2
- Housing Detail:** See **Housing H** in housing guide for dimensions
- Origin:** Made of US and non-US parts
- Track Mount:** 2.750" x 6.000"
MT212-6N Mounting Track Included
- Approvals:** UL Listed, UL916, C-UL, CE, RoHS

- Notes:**
- Circuit breaker for short protection.
 - 14/3 Line Cord included (3').
 - Use with UPS devices rated 1000 VA or less.
 - UPS is not included.